



HOHMANN & BARNARD, INC.
A MiTek - BERKSHIRE HATHAWAY COMPANY

Flashing and Reglets

Stretch-X-Seal™

Stretchable Flashing

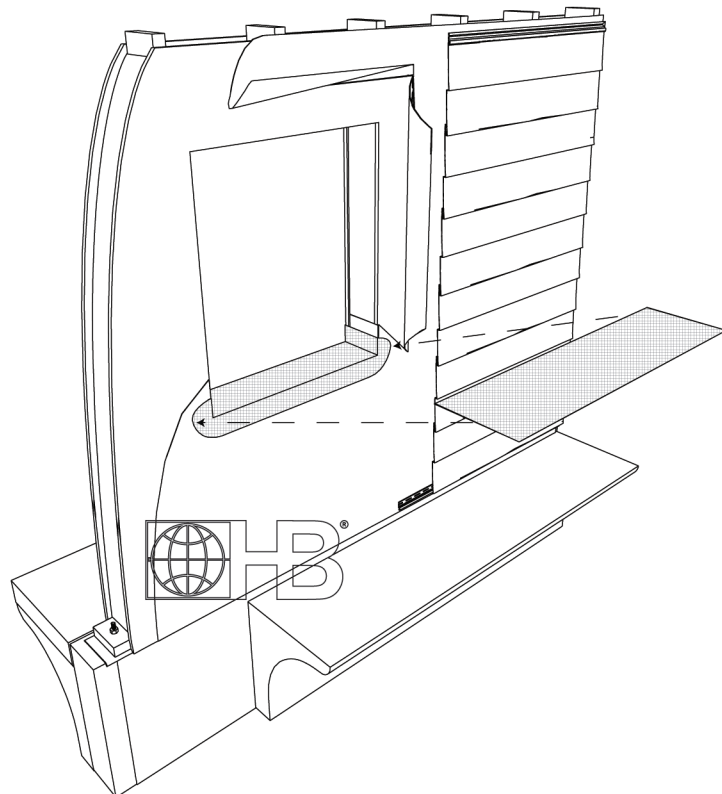
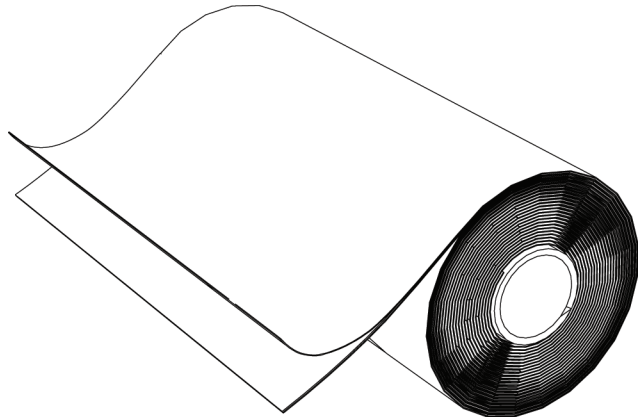

DRAWINGS FOR ILLUSTRATIVE PURPOSES ONLY

Stretch-X-Seal™

Flashing for Window Sills and Difficult Shapes

Stretch-X-Seal™ is a "stretchable" flashing tape made from an elastic non-woven polyolefin factory laminated to a proprietary adhesive.

- Adapts to difficult shapes: round top windows, window pans, and wall penetrations
- Adhesive is backed with a removable release liner.
- Available in 7", 9" & 11" wide (Other widths available upon request)
- 75 ft. long
- UV-resistant for 120 days
- Tear resistant
- Maintains performance in extreme temperatures

Patents Pending

Manufactured from 45% post-industrial and/or post-consumer recycled material.

* Please refer to Hohmann & Barnard installation instructions for more information.

Technical Data

- Tensile Strength - **ASTM D828**
 - Machine Direction 30 psi
 - Cross Direction 32 psi
- Trapezoid Tear - **ASTM D117**
 - Machine Direction 15 lbs
 - Cross Direction 17 lbs
- Water Vapor Transmission - **ASTM E96A**
28 perms
- Water Resistance - **ASTM D779**
Pass
- Air Permeance - **ASTM E2178-03**
< 0.001 L/s/m²

Roll Width: (rolls are 75 ft. long)

- 7" 9"
 11" OTHER _____

HOHMANN & BARNARD, Inc.
30 Rasons Court | Hauppauge, NY 11788
CORPORATE HEADQUARTERS
T: 800.645.0616 F: 631.234.0683
www.h-b.com

Branch/Subsidiary Locations:
ALABAMA - ILLINOIS - MARYLAND
NEW YORK - PENNSYLVANIA - TEXAS
CANADA

© HOHMANN & BARNARD, INC. - 2013