

Column and Beam Anchors

359FP & 359FP-C - Weld-On Ties

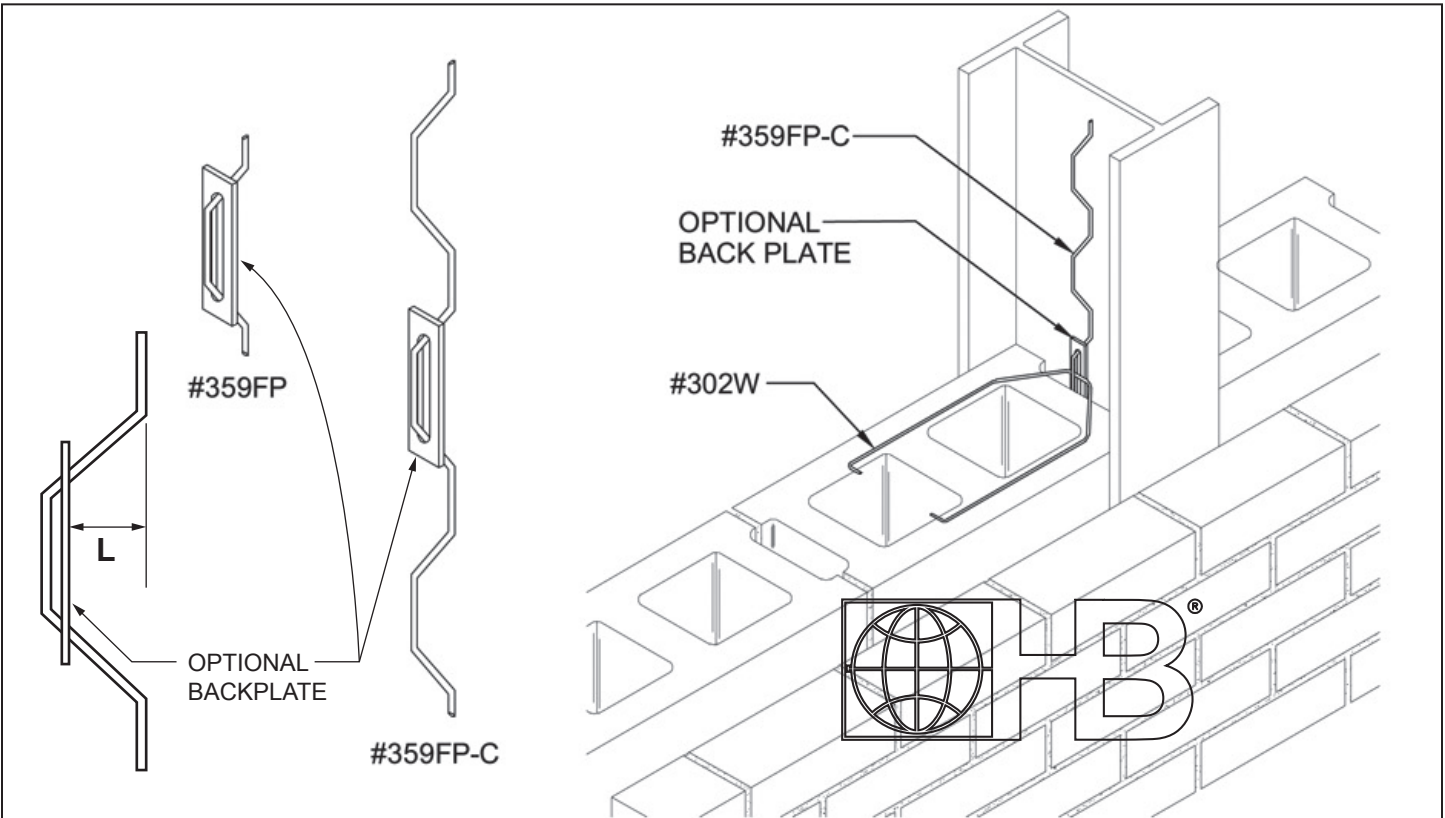

DRAWINGS FOR ILLUSTRATIVE PURPOSES ONLY

Description:

For use when there is a requirement for spray-on fireproofing. 359FP Weld-On Tie can be used in conjunction with Vee Byna-Tie® or #302W Column Web Tie to anchor masonry to structural frame while allowing vertical differential movements between steel and masonry.

Steel Rod (Carbon Steel):

ASTM A36/A36M
Zinc Plated - ASTM A108, ASTM A36/A36M, ASTM B633
Hot-Dip Galvanized - ASTM A153/A153M-B2

Steel Rod (Stainless Steel):

ASTM A582/A582M - AISI Type 304 Stainless Steel

Sheet Metal (Carbon Steel):

ASTM A1008/A1008M
Zinc Coating:
ASTM A641/A641M (0.1 oz/ft²) (Mill Galvanized)
ASTM A153/A153M-B2 Class B (Hot-Dip Galvanized after fabrication)
Note: H&B will certify to a minimum of 2.0 oz/ft²

Sheet Metal (Stainless Steel):

ASTM A 666, ASTM A480/480M, and ASTM A240/A240M
AISI Type 304 or 316

H&B manufactures steel wire products with recycled material.

- 359FP:**
3/8"Ø x 9" long
- 359FP-C:**
3/8"Ø x 8" long with offset 16" O.C.

Exaggerated Offset (Dimension "L")
(refer to illustration above)

359FP / 359FP-C Finish:

- Hot-Dip Galv. Stainless Steel: Type 304 Type 316

- Optional Back Plate** (restrains compressive loads)
1 1/2" x 12 gauge x 8" long

Optional Backplate Finish:

- Hot-Dip Galv. Stainless Steel: Type 304 Type 316

Note: H&B recommends Stainless Steel for maximum protection against corrosion.

IMPORTANT: Since each construction project is unique, the appropriate selection and use of any product contained herein must be determined by competent architects, engineers and other appropriate professionals who are familiar with the specific requirements of the project in question. This drawing and/or data sheet is the confidential and proprietary information of Hohmann & Barnard, Inc. and is not to be reproduced, copied or disclosed, in whole or in part, without the prior written consent of H&B.